



**Overhead Distribution General Information  
Utility Reference Specification  
Attachment of Communication Company  
Facilities on PPL Company Poles  
6-01-140**

0000-000-ST-6001  
Custom ID: DCS 6-01  
Revision: 12  
Effective Date: 05/04/2020  
Page 120 of 174

**6-01-140 – Utility Reference Specification – Attachment of Communication Cable Facilities on PPL Poles**

# **Requirements for the Attachment of Communication Cable Facilities on PPL Poles**

Replaces: URS-3002  
URS-3004  
URS-101C-304  
A-157649



**Overhead Distribution General Information  
Utility Reference Specification  
Attachment of Communication Company  
Facilities on PPL Company Poles  
6-01-140**

0000-000-ST-6001  
Custom ID: DCS 6-01  
Revision: 12  
Effective Date: 05/04/2020  
Page 121 of 174

**Reference Notes for Drawings:**

**General**

1. The term “communication cable facility” refers to facilities installed by telephone, CATV, telecommunication, and public/private companies for voice, video, or data transmission. The owner of the communication cable facilities must follow the proper attachment permit procedures as specified by the appropriate attachment agreement. Please reference PPL Specification 6-01-160 for wireless antenna installations.
2. Any rearrangement of PPL electrical facilities or other communication facilities necessary to accommodate the attachment of communication cable facilities on PPL poles must be negotiated by the communication cable facility owner with the existing facility owner and completed prior to making the attachment.
3. All new communication cables and cabinets shall be marked at each pole in a manner such that the ownership of the facility can be determined by PPL personnel from ground level. Existing communication cables and cabinets should be marked when maintenance is performed on that facility.
4. Bolt ends must not project more than one inch beyond the nut.

**Cable Attachments**

5. The communication cable must be attached directly to the pole surface or attached using metallic or fiberglass offset brackets. Offset brackets should only be used to provide the required horizontal clearance to buildings, signs, trees, and similar facilities or to reduce the change in direction (angle) of the communication cable. Offset brackets should not be used to avoid required vertical clearances.

Drilled holes in a wood pole shall be spaced a minimum of 4 inches vertically when they are parallel (in the same direction) through the pole. Drilled holes that are perpendicular (90 degrees apart) through the pole shall be spaced a minimum of 2 inches vertically.

Attachment to metal distribution poles must be clamped or banded to the poles with stainless steel straps. The drilling of holes in a metal pole for a bolt attachment is prohibited unless the applicant first obtains written authorization due to a highly unusual circumstance. All attachments to metal poles require prior approval of PPL engineering personnel.

Attachment to fiberglass poles should be treated like attachments to wood poles with the following exceptions:

- a) Attachment to fiberglass poles must be made using through bolts for the hardware.
- b) Lag screws are not permitted in fiberglass poles.



**Overhead Distribution General Information  
Utility Reference Specification  
Attachment of Communication Company  
Facilities on PPL Company Poles  
6-01-140**

0000-000-ST-6001  
Custom ID: DCS 6-01  
Revision: 12  
Effective Date: 05/04/2020  
Page 122 of 174

- c) DO NOT drill the attachment hole at the same height as the pre-drilled climbing holes are located.
  - d) The attachment holes should have a minimum distance of 2 inches vertically from the pre-drilled holes.
  - e) DO NOT drill holes where the distance of the edge of that hole would be within 2 inches from the edge of any existing hole.
6. The use of wood arms for any communication cable attachments is not permitted for new installations, except with the prior written approval of PPL engineering personnel for each specific attachment location.
7. Service Drop – a single wired drop installed to provide communications service to an individual customer, starting at the customer’s premises and extending to the closest available utility pole, without requiring any additional anchors or guying to comply with all applicable engineering standards. A communication service drop may attach in-span or directly to a single pole. When attaching a communication service drop cable to a pole, it must be submitted in the Application Portal to ensure compliance with this definition and to ensure that the communication service drop is accounted for as an attachment.

A communication service drop may extend more than one pole, upon review and approval by PPL, when the following conditions are met:

- a) where it is necessary to maintain code required ground or roadway clearance, a second pole may be used to provide support for the single communication service drop cable; or
- b) on private property when all the following conditions are met:
  - i) it is a single wired drop;
  - ii) submitted in the Application Portal;
  - iii) all poles associated with the service drop are on a single private property; and
  - iv) the communication service drop is no more than 500’ in length measured from the customer’s premises

### **Clearance Requirements**

8. Clearance between PPL electrical facilities and communication cable facilities must be in accordance with the latest edition of the National Electrical Safety Code (NESC). Use Section 23 of the NESC to determine the clearances required at the pole and in-span. It specifies that the required vertical clearances must be measured surface-to-surface, not center-to-center. Diagonal measurements do not apply to electrical clearances. Additional vertical clearance may be needed on the pole to achieve the required in-span clearances.

Communication reinforcing straps should be considered when measuring vertical clearances between communication facilities and electrical facilities.



**Overhead Distribution General Information  
Utility Reference Specification  
Attachment of Communication Company  
Facilities on PPL Company Poles  
6-01-140**

0000-000-ST-6001  
Custom ID: DCS 6-01  
Revision: 12  
Effective Date: 05/04/2020  
Page 123 of 174

9. The in-span vertical clearance as specified by the NESC in Rule 235 between the lowest electrical conductor and the highest communication cable is 30 inches based on the following conditions:
- a) The upper conductor is at final sag at 120°F or the maximum conductor operating temperature and the lower conductor is at final sag at the same ambient conditions as the upper conductor without electrical loading, or
  - b) The upper conductor is at final sag at 32°F with a 1/2 inch radial ice thickness and the lower conductor is at final sag at the same ambient conditions as the upper conductor without electrical loading and without ice.

When the bottom PPL conductor is a neutral, multiplex secondary, or primary aerial cable and is bonded to the communications messenger at the intervals specified in Note 32, the in-span vertical clearance at maximum sag must not be less than 12 inches. This exception also applies to all dielectric-self-supporting fiber optics cable, which cannot be electrically bonded.

10. The minimum clearance between communication cables (center-to-center) supported by different suspension strands must be 12 inches at the pole and 6 inches in span. In most cases, this will be a vertical clearance, but when communication cables are located on opposite sides of the pole, the 12 inches vertical clearance may be reduced provided that the minimum diagonal clearance is 12 inches and the bolts are a minimum of 6 inches apart. A minimum vertical clearance of 6 inches must be maintained between any strand-mounted equipment of cable expansion loops and the communication cables below. Reduced spacing is permitted if agreed to by the existing communication cable owner and communicated to PPL in writing. Reinforcing straps should not be considered when measuring clearances at the pole between communication cable facilities.
11. The vertical clearance for communication cables facilities above ground and paved surfaces at the low point in the span must be in accordance with NESC Table 232-1, state, or local regulations (typical values given below):
- f) 9.5 feet to ground over spaces accessible to pedestrians only
  - g) 15.5 feet to ground over spaces subject to truck traffic such as roads, streets, driveways, parking lots, and alleys
  - h) 18 feet to travelled way and shoulders within the right-of-way of Pennsylvania state highways
  - i) 23.5 feet to travelled way and shoulder within the right-of-way of the Pennsylvania Turnpike
  - j) 35 feet to the top of rail of railroad tracks that may have double high container cars



**Overhead Distribution General Information  
Utility Reference Specification  
Attachment of Communication Company  
Facilities on PPL Company Poles  
6-01-140**

0000-000-ST-6001  
Custom ID: DCS 6-01  
Revision: 12  
Effective Date: 05/04/2020  
Page 124 of 174

12. Any in-span service drop or device mounted on a communication cable or messenger must be a minimum of 15 inches from the pole face at its nearest point to assure adequate climbing space.
13. Effectively grounded communication cable facilities passing near a PPL structure without being attached thereto shall have a horizontal clearance, without wind, from any part of such structure of not less than three feet. Ungrounded communication cable facilities shall have a horizontal clearance, without wind, from any part of such structure of not less than five feet (per NESC Rule 234B).
14. A vertical run of communication cable attached to the pole surface should be covered with a suitable non-metallic material and must have the following clearance from through bolts or other metallic objects which are associated with PPL equipment:
  - a) one-eighth of pole circumference, or
  - b) two inchesWhichever value is greater

**Cable Position**

15. The usable space on the pole as defined by the FCC is that pole space 18 feet and higher above ground level. The top of the usable pole space is reserved for PPL electrical attachments. The middle portion of the usable pole space is reserved for third party (Telcom, CATV, and public/private) communication cable or service drop attachments. The recommended minimum height of the initial third party cable attachment is 23 feet if conditions permit. The bottom portion of the usable pole space is reserved for the communication cable or service drop attachments owned by the incumbent telephone company. The recommended maximum height for the initial telephone cable attachment is 21 feet if conditions permit or lower if possible.
16. All communication cables must be attached to the roadside side of the pole unless approved in writing by PPL. Back bolting and back attachments will not be approved on poles that are 60 feet or greater in size.
17. In limited situations, PPL may allow the use of a bolt extender and communication cable to attach on the same side of the pole as the existing communication cable as long as the owner of the proposed communication cable owns the bolt and existing communication cable. All requests to use a bolt extender must be approved by PPL in writing through the application process. No more than 2 cable attachments are permitted on a single bolt.
18. The owner of the proposed communication cable shall not “weave” its cables from one vertical position to another with respect to other communication cables on the same sides of the pole line route. “Weaving” from one side of the pole to the other along the pole line route (except where it crosses a road) is also not permitted.



**Overhead Distribution General Information  
Utility Reference Specification  
Attachment of Communication Company  
Facilities on PPL Company Poles  
6-01-140**

0000-000-ST-6001  
Custom ID: DCS 6-01  
Revision: 12  
Effective Date: 05/04/2020  
Page 125 of 174

## **Guying**

19. The owner of the communication cable facility must guy unbalanced loads imposed on the pole by dead ending or changes in direction of the communication cable facility per Bellcore specifications for guying communication cables. The communication cable facility must not alter the vertical position of PPL poles or change the sag characteristics of PPL conductors.
20. The proposed communication cable facility should be installed with the proper tension so that its final sag meets clearance requirements to existing electrical and communication facilities. There should not be more than one reduced tension span, maximum 100 feet in length, in consecutive spans without PPL approval.
21. All guying must be installed prior to the installation of the communication cable facility. Guy wires may be attached to PPL poles or anchor rods provided that the PPL facility has sufficient unused strength to support the proposed communication cable facility. The number of guy wires to one anchor rod may not exceed the number of eyes on the anchor rod plus one auxiliary eye attachment.
22. If the PPL anchor rod cannot support an additional guy wire attachment, the owner of the proposed communication cable facility must make provisions to install another anchor rod at least 6 feet from the PPL anchor rod.
23. The spacing (center-to-center) between adjacent guying attachments or between adjacent communication facility and guying attachments should not be less than six inches.

## **Underground Communication Cable Risers**

24. The number of underground (UG) electric and communication cable risers attached directly to the pole surface should be limited so that one side (180 degrees) of the pole is kept clear for climbing space and replacing the pole. UG communication cable risers should be located on the same side of the pole as their overhead communication cables are attached.
25. Riser standoff brackets may be used as necessary to provide the required 180 degrees of clear pole space. The UG communication cable risers should be on the same side of the pole as the riser standoff brackets or, if the positions are available, occupy the end conduit positions on the bracket.
26. Underground communication cable risers should not be installed on poles supporting transmission circuits operating at 69 kV and 138 kV.

## **Cabinets by Utility Companies**

27. Cabinets and powered equipment may be mounted directly on the pole in the unusable space (defined as that pole space less than 18 feet above ground level). PPL must approve in writing the pole chosen prior to the installation of all new cabinets and powered equipment to confirm that the pole is suitable. Passive equipment, such as slack loops and splice



**Overhead Distribution General Information  
Utility Reference Specification  
Attachment of Communication Company  
Facilities on PPL Company Poles  
6-01-140**

0000-000-ST-6001  
Custom ID: DCS 6-01  
Revision: 12  
Effective Date: 05/04/2020  
Page 126 of 174

cases shall be suspended from the communication cable messenger. All exceptions must be approved by PPL in writing.

Do not install any new pole-mounted cabinets and service entrance equipment on:

- a) Junction poles (a pole where the PPL primary line runs in four or more directions)
- b) Poles that are 60 feet and greater in size or made of metal
- c) Poles with transmission facilities (69 kV and 138 kV) attached
- d) Poles with cabinets already installed by any communication company
- e) Poles with cabinets containing controls such as fire alarm, police signal, or traffic signal
- f) Poles with capacitor controls, regulator controls, recloser controls, air switch operating handles, or an existing electrical service entrance
- g) Transformer poles which are not accessible to mechanized equipment
- h) Poles with underground electric or communication riser conduits which are not accessible to mechanized equipment

A new cabinet can be installed on a pole with an existing cabinet if both cabinets are owned by the same company, the new cabinet is part of a rebuild project and the existing cabinet will be removed upon rebuild project completion, and no other reasons for exclusion (as listed above) exist.

28. The maximum size pole-mounted cabinet allowed is 31 inches wide x 19 inches deep x 38 inches high. Climbing aids are required when cabinets larger than 30 inches high are installed. The climbing aid can be a 3/4 inch bolt approximately 22 inches long, projecting 8 inches from each side of the mounting channel, secured by four nuts at the channel, and mounted half way up the channel. Cabinets must be mounted using externally accessible hardware. There must be only one cabinet installed on any one pole. Any metallic cabinet must be effectively grounded.
29. The minimum vertical clearance from the top of the cabinet to the lowest communication cable facility is 31 inches. The minimum vertical clearance from the bottom of the cabinet above ground must be in accordance with NESC Table 232-2 (typical values given below):
  - a) 11 feet to ground over spaces accessible to pedestrians only
  - b) 15 feet to ground over spaces subject to truck traffic such as streets, alleys, driveways, and parking lots
30. Install and effectively ground meter bases and disconnect switches in accordance with the latest revision of PPL "Rules for Electric Meter and Service Installations" except for the



**Overhead Distribution General Information  
Utility Reference Specification  
Attachment of Communication Company  
Facilities on PPL Company Poles  
6-01-140**

0000-000-ST-6001  
Custom ID: DCS 6-01  
Revision: 12  
Effective Date: 05/04/2020  
Page 127 of 174

mounting height of the meter (6-1/2 feet from centerline to ground as shown in Figures 6-01-140-C & 6-01-140-D of this specification).

31. Meter troughs, meter trough covers, and service conduit and hubs shall not be used for communication grounds.
32. On 4kV, 12kV, & 13kV multi-grounded PPL lines, the owner of the communication cable facility must install and maintain an electrical bond between the metallic communication cable or messenger and the PPL vertical pole ground wire. There must be at least four bonds per mile with not more than 1,500 feet between these bonding locations. Make the electrical bond using #6 AWG copper wire and connectors suitable for the purpose. Communication cable that is entirely dielectric (non-conductive) need not be bonded.
33. Where there is an existing vertical ground wire connected to PPL's multi-grounded neutral system, the owner of the communication cable facility shall connect the bond wire to the vertical ground wire keeping the bond wire as short as practical. Where there is no vertical ground wire, the owner of the communication cable facility shall place a coiled length of bond wire connected to its facilities and notify PPL to connect the bond wire to the multi-grounded neutral system.
34. All communication cable facility guy wires must be bonded to an effectively grounded communication cable suspension strand, the PPL vertical pole ground wire, or to an adjacent PPL guy wire if no PPL vertical pole ground wire exists.
35. On PPL lines which are not multi-grounded (normally 23kV and higher voltage circuits), the owner of the communication cable facility must **not** bond either its guy wire or its metallic communication cable to any PPL vertical pole ground wire unless specifically directed to do so by PPL engineering personnel. The owner of the communication facilities must install and maintain its' own grounding wire and grounding electrode (ground rod).

### **Emergency Electric Supply**

36. Generators or other means for emergency electric supply to communication cable facilities are prohibited unless specifically approved by PPL engineering personnel in writing. Installations of emergency electric supply equipment must conform to the latest revision of PPL "Rules for Electric Meter and Service Installations". The type of device to be used must ensure that there cannot be an interconnection between the emergency electric supply and the PPL electric system.

### **Transmission Pole Attachments**

37. Attachment personnel can permit cable or guying attachments to transmission pole lines without additional follow-up if the poles are located on public R/W and already have electric distribution line facilities attached. The communication cable or guying attachments must be located below the electric distribution line facilities.





**Overhead Distribution General Information  
Utility Reference Specification  
Attachment of Communication Company  
Facilities on PPL Company Poles  
6-01-140**

0000-000-ST-6001  
Custom ID: DCS 6-01  
Revision: 12  
Effective Date: 05/04/2020  
Page 128 of 174

38. The attachment method for communication cable facilities must first be reviewed by the local Transmission Maintenance Engineer and then by System Transmission Design, in accordance with PPL's existing Encroachment Guideline. Only after this review has been completed and written approval granted can the attachment request be permitted.
39. Transmission lines are normally located within private R/W easements that do not permit PPL to grant attachment rights to other companies. Encroachment rights on this private R/W easement must first be granted by the property owner and presented to PPL before PPL can grant the right to attach to its transmission poles or structures.
40. The attachment of communication cable facilities is not permitted on poles supporting transmission circuits operating at voltages greater than 138 kV, unless an OHGW can be replaced with an OPGW.
41. No longitudinal third party owned fiber optic cable attachments are permitted on the overhead transmission system (69 kV and above) unless it is in the communication space on an under built distribution circuit and is located within the confines of public right-of-way.
42. If there are no electric distribution line facilities attached to the transmission poles, the attachment must follow PPL's Indefeasible Right of Use (IRU) approval process.
43. PPL plans to eventually replace its 69 kV and 138 kV wood poles with metal poles. Attachers must be prepared to change their method of attachment.



**Overhead Distribution General Information  
Utility Reference Specification  
Attachment of Communication Company  
Facilities on PPL Company Poles  
6-01-140**

0000-000-ST-6001  
Custom ID: DCS 6-01  
Revision: 12  
Effective Date: 05/04/2020  
Page 129 of 174

**Attachment of Communication Cables**

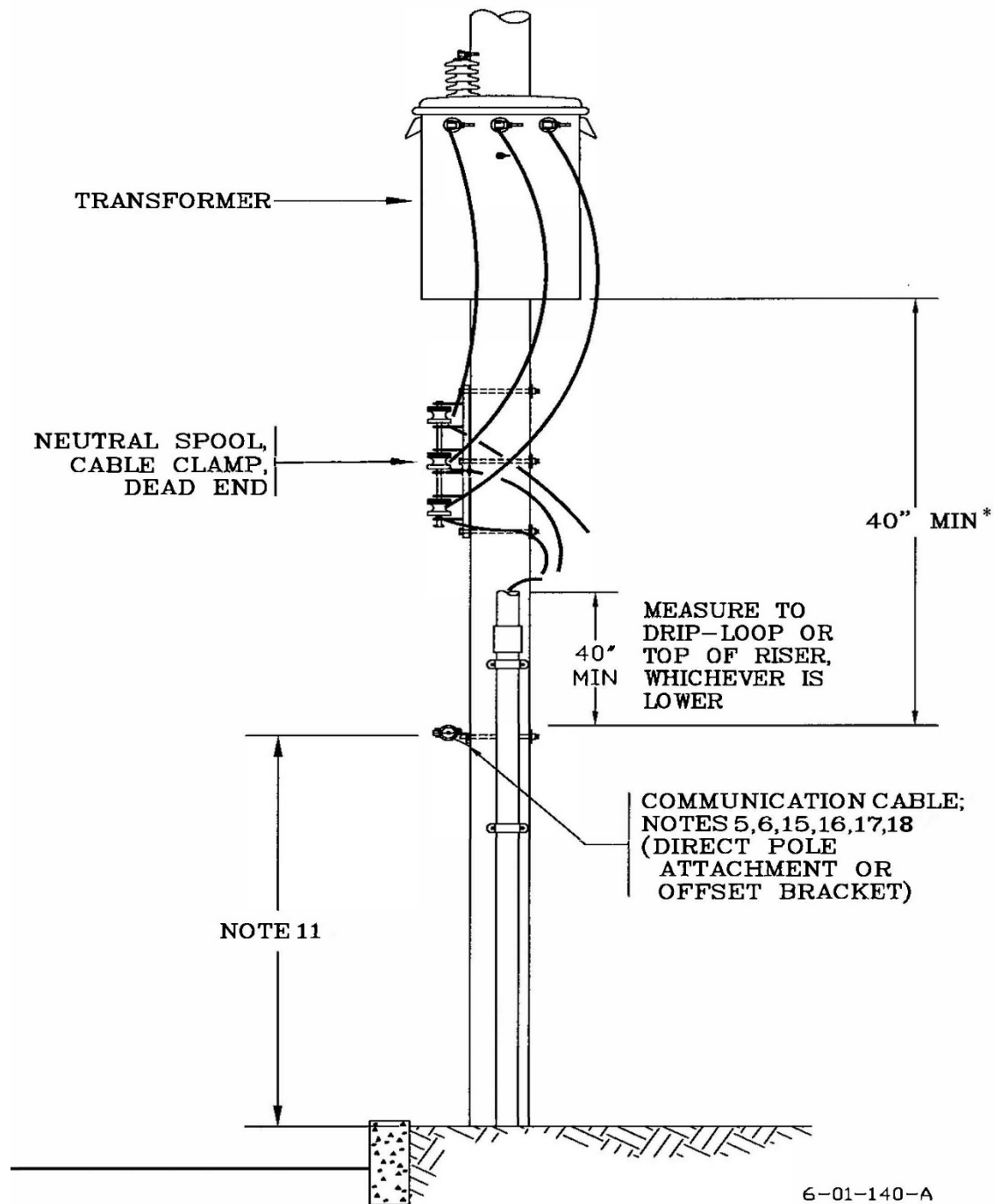

\*Note: Can be reduced to 30" minimum to neutral, primary underground cable or primary cable assembly if attaching cable company bonds to PPL EU's vertical ground wires. See Note 31.

**Attachment of Communication Cables**

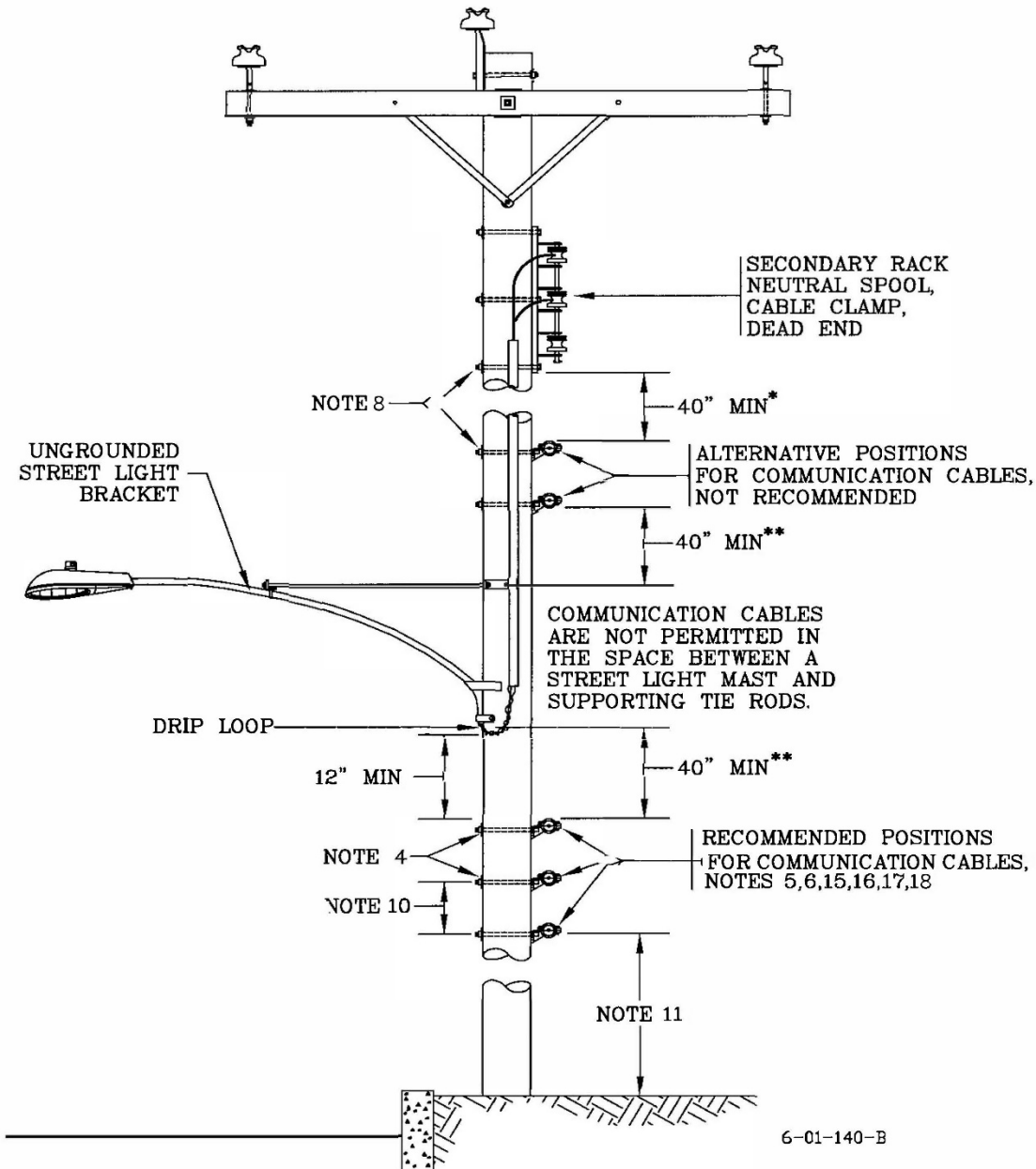

\*Note: Can be reduced to 30" minimum to neutral, primary underground cable or primary cable assembly if attaching cable company bonds to PPL EU's vertical ground wires. See Note 31.

\*\*Note: 40" minimum may be reduced to 4" if the streetlight bracket is grounded. A minimum clearance of 12" is still required from the communication cable bracket to the streetlight drip loop. To effectively ground street light bracket, use PPL CID 1029820.

**Attachment of Communication Cables**

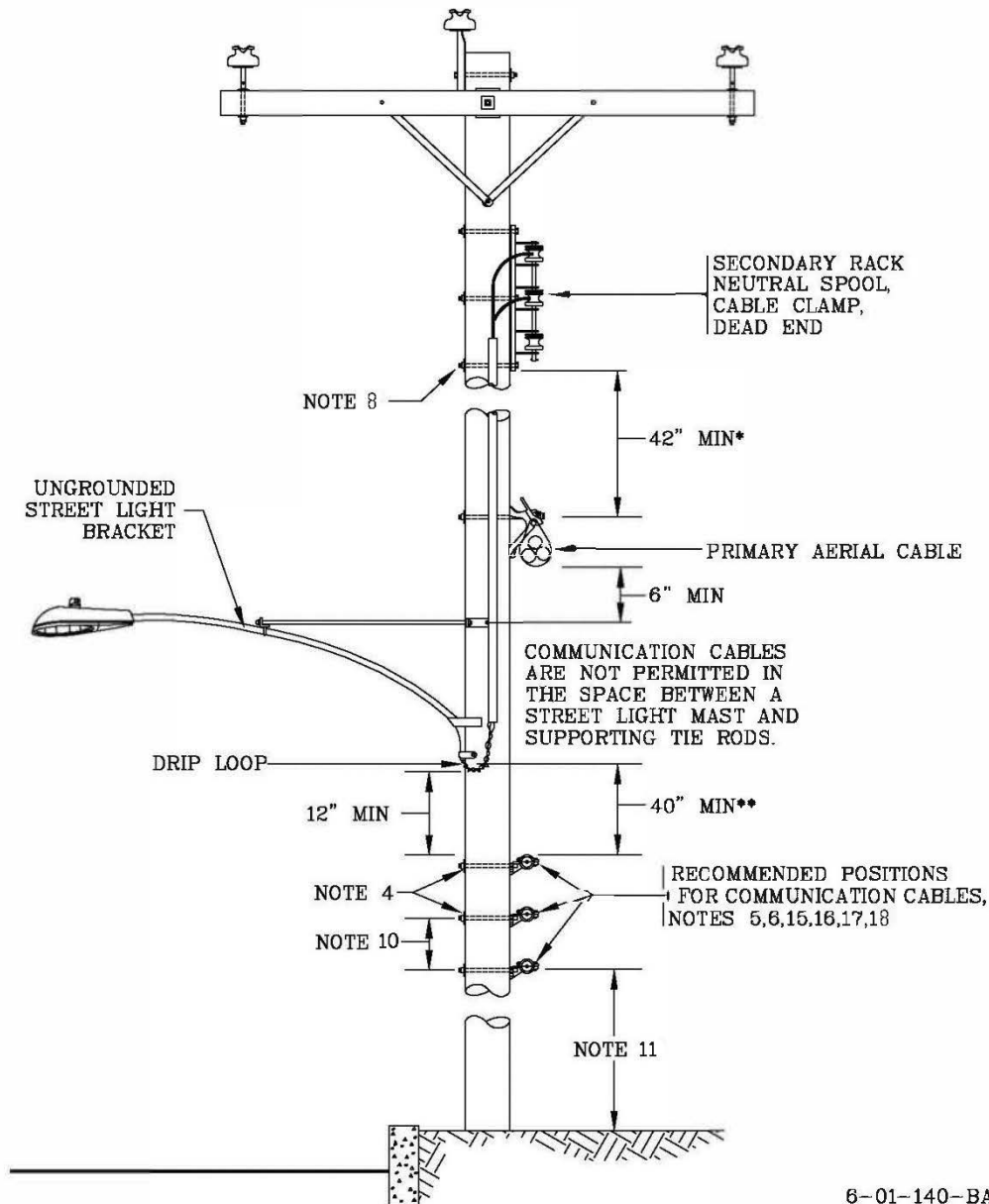

\*Note: Can be reduced to 30" for spans under 175 feet.

\*\*Note: 40" minimum may be reduced to 4" if the streetlight bracket is grounded. A minimum clearance of 12" is still required from the communication cable bracket to the streetlight drip loop. To effectively ground street light bracket, use PPL CID 1029820.



**Overhead Distribution General Information  
Utility Reference Specification  
Attachment of Communication Company  
Facilities on PPL Company Poles  
6-01-140**

0000-000-ST-6001  
Custom ID: DCS 6-01  
Revision: 12  
Effective Date: 05/04/2020  
Page 132 of 174

**Attachment of Cabinet and Service: Strand Mounted Cabinet**

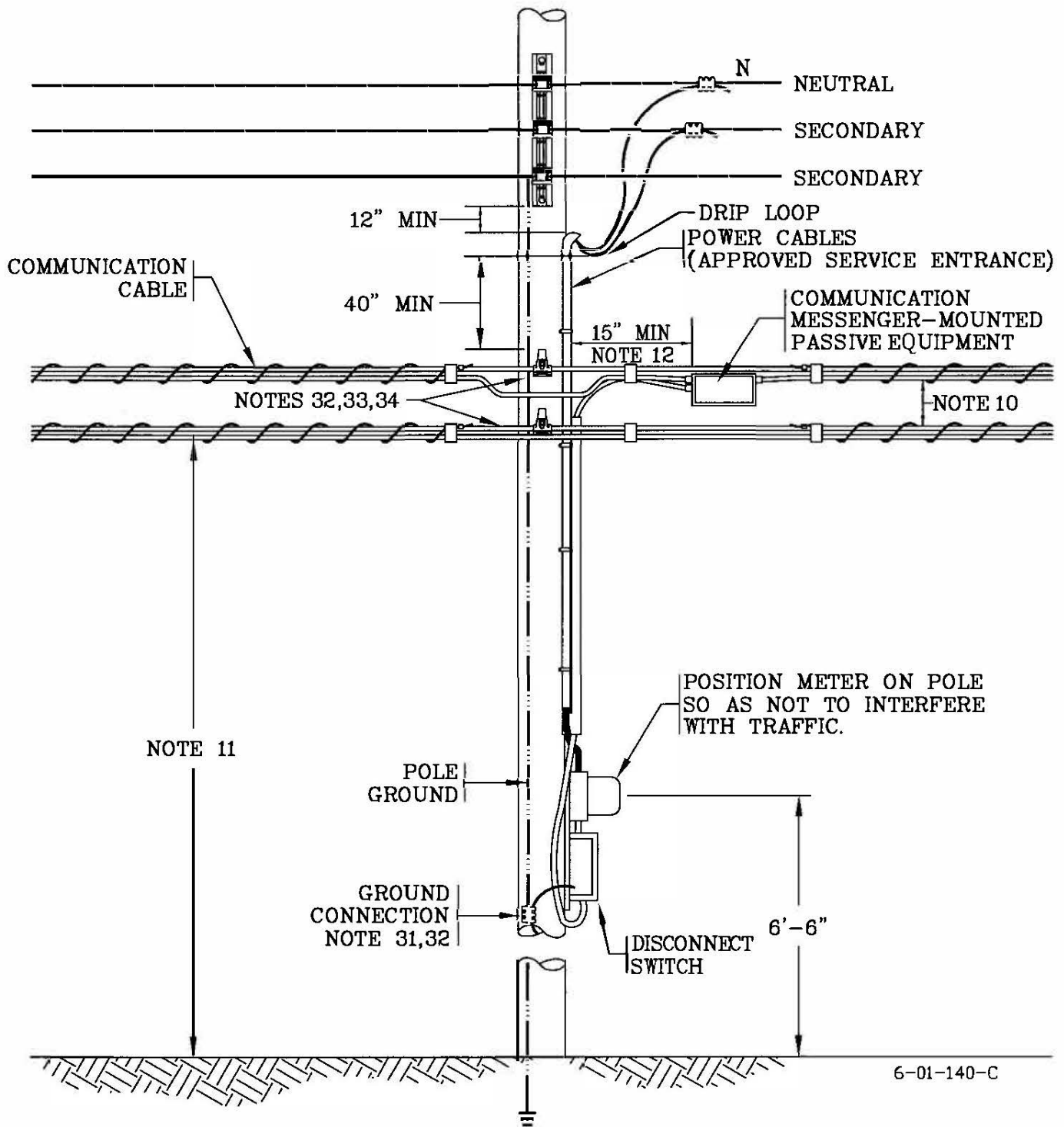

**Attachment of Cabinet and Service**

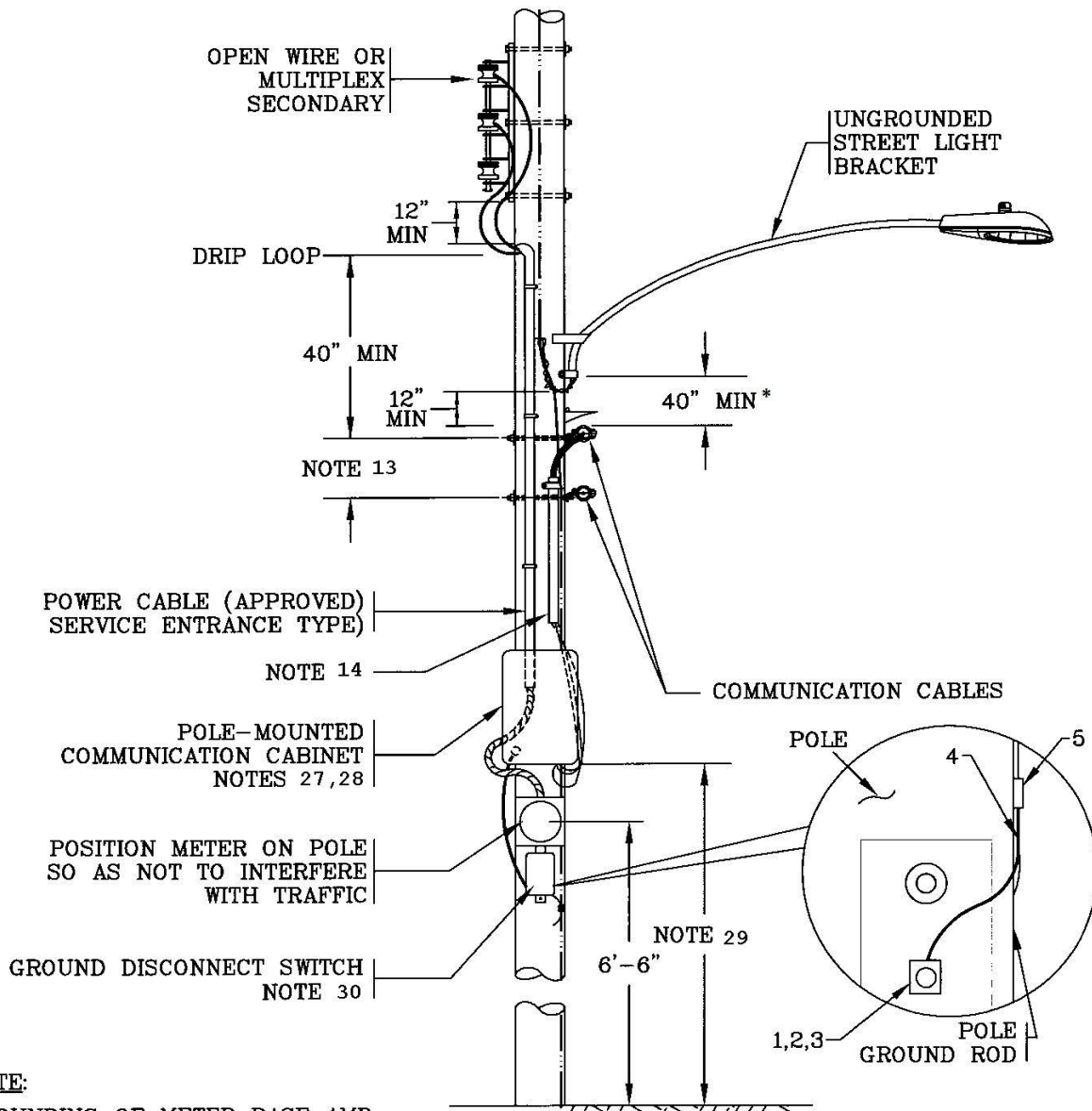

**NOTE:**

GROUNDING OF METER BASE AND DISCONNECT SWITCH IS REQUIRED.  
DETAIL ON THIS PAGE IS FOR GROUNDING PROCEDURES ONLY. LOCATION AND ROUTE OF GROUND IS TO BE DETERMINED BY FIELD ON A SITE BY SITE BASIS.

BILL OF MATERIAL: GROUNDING DETAIL			
ITEM	QUANTITY	DESCRIPTION	CATALOG #
1	1	TERMINAL CONNECTOR 1/2"	110390
2	1	SPLIT SPRING LOCK WASHER 1/2"	115441
3	1	BOLT WITH NUT 1/2"	106186
4	AS NEEDED	#4 COPPER (232#6) GROUND WIRE	147755
5	1	H-SHAPE CONNECTOR	108902

8-01-140-D

\*Note: 40" minimum may be reduced to 4" if the streetlight bracket is grounded. A minimum clearance of 12" is still required from the communication cable bracket to the streetlight drip loop. To effectively ground street light bracket, use PPL CID 1029820.

**Attachment of Communication Cable Risers**

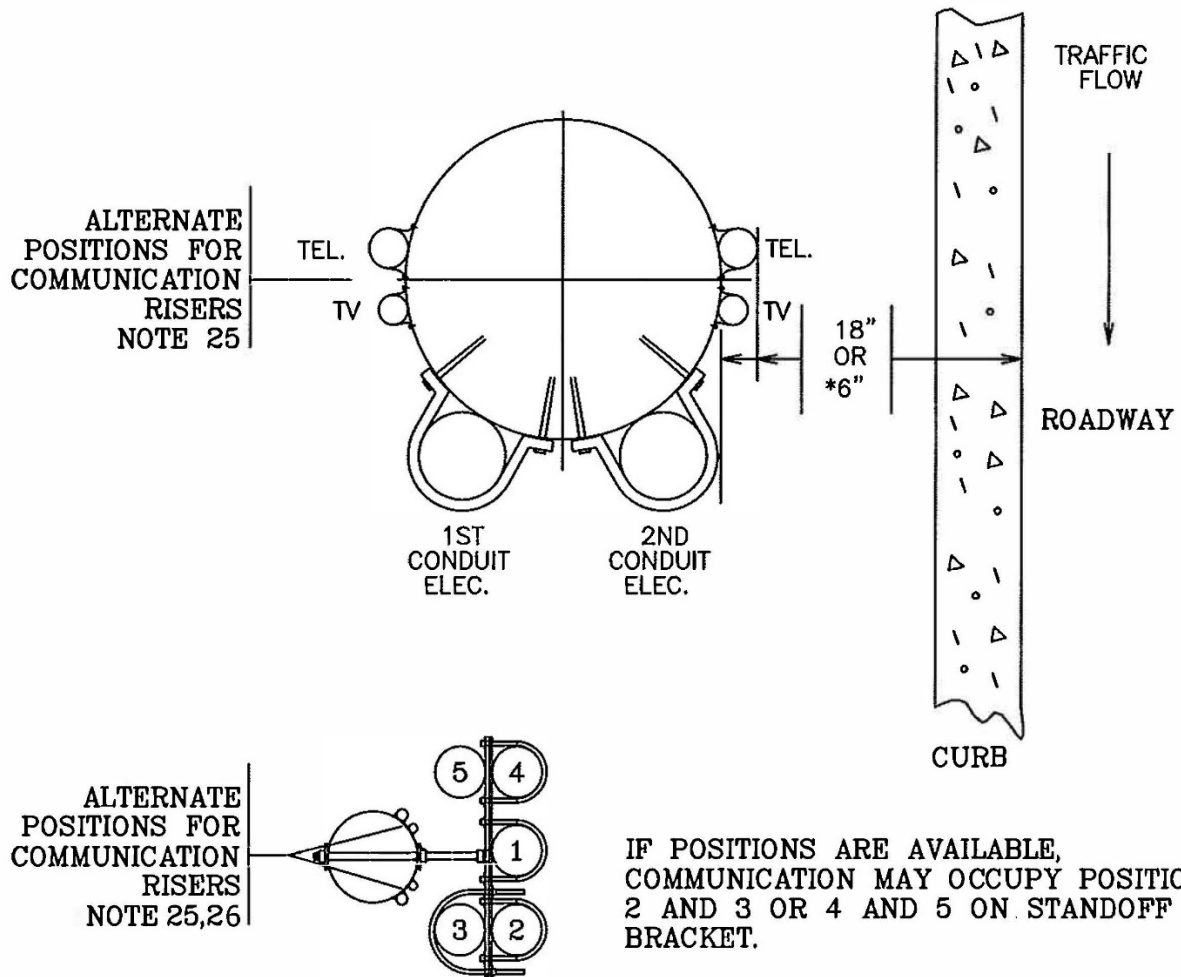

6-01-140-E

Cabinets, junction boxes, pedestals, etc. must not be attached to riser poles.

\*Note: Along PA-DOT roadways, 18" minimum is required. At new installations, 18" minimum is recommended. The National Electrical Safety Code requires 6" minimum clearance to both the pole and riser.